

**HOBART**701 S Ridge Avenue, Troy, OH 45374  
1-888-4HOBART • www.hobartcorp.com**C64A  
DISHWASHER****HOBART****STANDARD FEATURES**

- 244 racks per hour
- Opti-RinSe™ system
- Ball detent clutch conveyor drive mechanism
- Top mounted controls
- Stainless steel anti-clogging wash arms
- Stainless front panel, frame and legs
- Automatic fill
- Auto-timer
- Scrap screen and deep basket system
- Stainless steel self-draining pump and impeller
- Fixed pump intake screen
- Door actuated drain closure
- Door interlock switch on all doors
- Vent fan control
- Convertible hot water or low temp final rinse
- Booster heater control

**DIRECTION OF OPERATION**

- Right to Left
- Left to Right

**VOLTAGE**

- 208/60/3
- 240/60/3
- 480/60/3

**OPTIONS AT EXTRA COST**

- Stainless steel pressureless 15 kw or 30 kw booster heater
- Single point electrical connection (does not include booster heater)
- 6" higher than standard chamber
- Conveyor dwell
- Side loader
- Blower-dryer

**MODEL**

- C64A – Dishwasher

**ACCESSORIES**

- Stainless steel vent hoods
- Direct drive unloader
- Side loader

Specifications, Details and Dimensions on Inside and Back.

**C64A DISHWASHER**

# C64A DISHWASHER

**HOBART**

701 S Ridge Avenue, Troy, OH 45374  
1-888-4HOBART • www.hobartcorp.com

## C-LINE DISHWASHER NOW STANDARD WITH MORE PRODUCTIVE FEATURES THAN EVER . . .

Inside and out the C-Line Hobart dishwashers are packed with standard components and design innovations that make them the biggest value in the dishwasher industry.



**Stainless Steel Self-Draining Pump and Impeller.** Pump and impeller are stainless steel for maximum durability. A fixed pump intake screen prevents debris from entering into the pump.



**Wash Arms.** Computer-designed wash arms resist clogging, easily removed for cleaning.



**Opti-RinSe™.** Hobart's exclusive patent pending Opti-RinSe™ significantly reduces operating cost by reducing rinse water and the energy required to heat the water. The unique spray pattern uses large droplets to more efficiently sanitize the ware.



**Lift-Out Scrap Basket.** Screen design sheds soil more easily than flat screens, reduces frequency of cleaning — easy to empty large soil particles . . . Just lift out scrap basket.

## OPTIONAL BOOSTER HEATER



**Built-in Pressureless Stainless Steel Booster Heater.** Inter-wired and interplumbed. Saves on installation and saves floor space. Simplifies operation with just one switch to power dishmachine and booster.

## OTHER STANDARD FEATURES . . .

- **Low-Temp Convertibility In Field.** Order your C-Line with hot water sanitizing or energy-saving low temperature chemical sanitizing — then, if requirements change, convert from one mode to the other in the field. An exclusive feature — standard from Hobart.
- **Auto-Fill.** One button automatic fill ensures optimum tank level, and the simplest operation.
- **Auto-Timer.** Automatically activates the warewasher when a rack enters the machine, and after the last rack has passed, shuts off the pump and conveyor, while maintaining tank heat temperature. Extends machine life, requires less operator attention and promotes significant energy savings.
- **Door Actuated Drain Closures.** Closing the door automatically actuates drain closures, eliminates extra manual steps, insures that closures are in the correct position.
- **Vent Fan Control and Booster Heater Control.** Allows for interconnection to dishwasher.



701 S Ridge Avenue, Troy, OH 45374  
1-888-4HOBART • www.hobartcorp.com

# C64A DISHWASHER

## AVAILABLE OPTIONS . . .

Flexibility is synonymous with Hobart C-Line dishwashers. If your operation demands a dishwasher with a vent hood, an extended hood . . . a recirculating prewash, just specify the combination of options that suit your needs.



**Side Loader.** Save up to 20 square feet in the dishroom layout with an optional C-Line Side Loader. Racks are indexed 90° into the dishwasher automatically – a feature that cuts space and reduces labor dramatically. Your dishroom team will appreciate this feature.



**Extended Hood**

**Vent Hood**

C-Line Dishwashers are available with vent hoods or extended hoods, each with vent stack and locking-type damper, and both designed to fit either end of the dishwasher.

## OTHER AVAILABLE OPTIONS . . .

Condenser, blower-dryer, conveyor dwell, steam booster heater, low-temp final rinse system and a single-point electrical connection for electric heat machines.

## SPECIFICATIONS

Hobart Model C64A to operate in a \_\_\_\_\_ to \_\_\_\_\_ direction. Voltage and phase to be \_\_\_\_\_. Tank heat to be \_\_\_\_\_. Unit to be a minimum length of 64". Motor controls wired to a common electrical point in stainless steel top mounted control box. Wash arms to be removable without tools. Drain handle to be located inside tank chamber and to be automatically closed when inspection door is closed. Final rinse to be no more than 4.6 gpm.

	<b>C64A</b>
<b>Machine Ratings (Mechanical)</b>	
Racks per hour (19¼" x 19¼")	244
Conveyor Speed - feet per minute	6.8
Dishes per Hour (Average 25 per rack)	6,100
Glasses per Hour (Average 45 per rack)	10,980
<b>Floor Space - Table to Table (Inches)</b>	63⅞
<b>Overall Dimensions - H x W x D (Inches)</b>	70¼ x 65⅞ x 30¼
<b>Motor</b>	Wash 2 – Rinse 2
<b>Conveyor Drive</b>	⅓
<b>Blower-Dryer - Motor H.P. (if used)</b>	2
<b>Electric Blower Dryer</b>	
Heating Coils (if used)	42.0 KW
<b>Blower-Dryer - Based on 20 PSI</b>	
Flowing Steam if used (25 PSIG MAX.)	110
<b>Number of Tanks</b>	2
<b>Tank Capacity - Gallons</b>	Wash 23 – Rinse 23
<b>Pump Capacity -</b>	
Gallons per Minute - Weir Test	Combined 208
<b>Heating Equipment - (For keeping power wash hot)</b>	
Gas Burners (with Natural Gas) - BTU per hr.	94,000
Steam Injectors	Regulated ¾"
Electric Heating Unit - Size Used	Regulated 25 KW (15 - 10)
<b>Optional Booster Heater / Final Rinse</b>	15 KW / 30 KW
<b>Rinse - Minutes operated during hour of maximum operation</b>	60
<b>Final Rinse Flow - Gals. per min.</b>	
At 15 PSI Flow Pressure	1.92
At 20 PSI Flow Pressure	2.21
<b>Final Rinse Flow - Gals. per hr. - MAXIMUM</b>	
At 15 PSI Flow Pressure	116
At 20 PSI Flow Pressure	133
<b>Rinse 20 PSI Flow Pressure</b>	
Gal./Rack	Hot Water Sanitizing - Chemical Sanitizing .55 - 180°F – .55 - 140°F
<b>Steam Consumption - Pounds per hr. - MAXIMUM</b>	
Approx. 30 lbs. per hr. = 1 boiler H.P. (BHP)	
<b>Dishwasher</b> , based on 20 PSI steam and on customer supplying final rinse water at 180°F maximum	130
<b>Steam Booster</b> , if used on 20 PSI steam - 20 PSI water flowing - 130°F entering water raised to 180°F min.	65
<b>Exhaust Requirements - Cubic Feet per minute</b>	
Entrance End	200
Discharge End	400
Discharge End w/Blower Dryer	1400
<b>Peak Rate of Drain Flow - Gallons per minute.</b>	
(Initial rate with full tank)	38
<b>Shipping Weight Crated - Approximate lbs.</b>	880

# C64A DISHWASHER



701 S Ridge Avenue, Troy, OH 45374  
1-888-4HOBART • www.hobartcorp.com

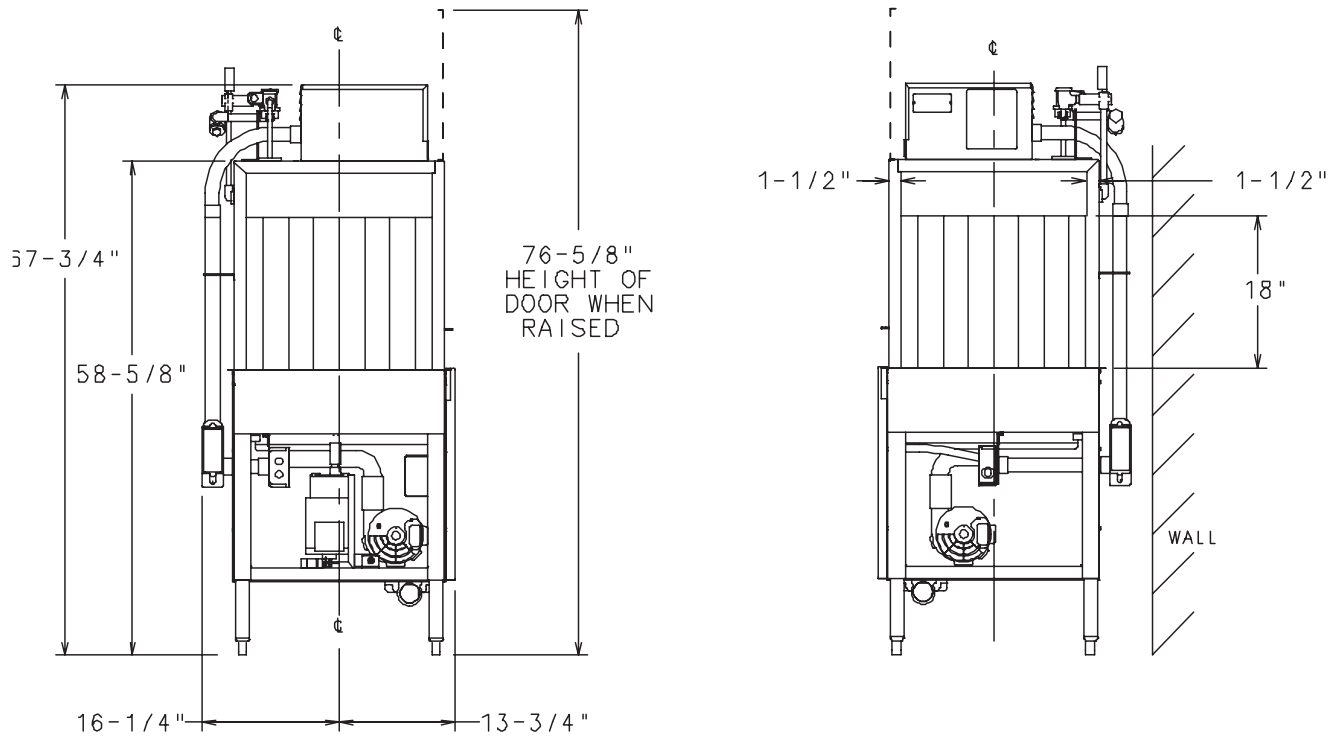
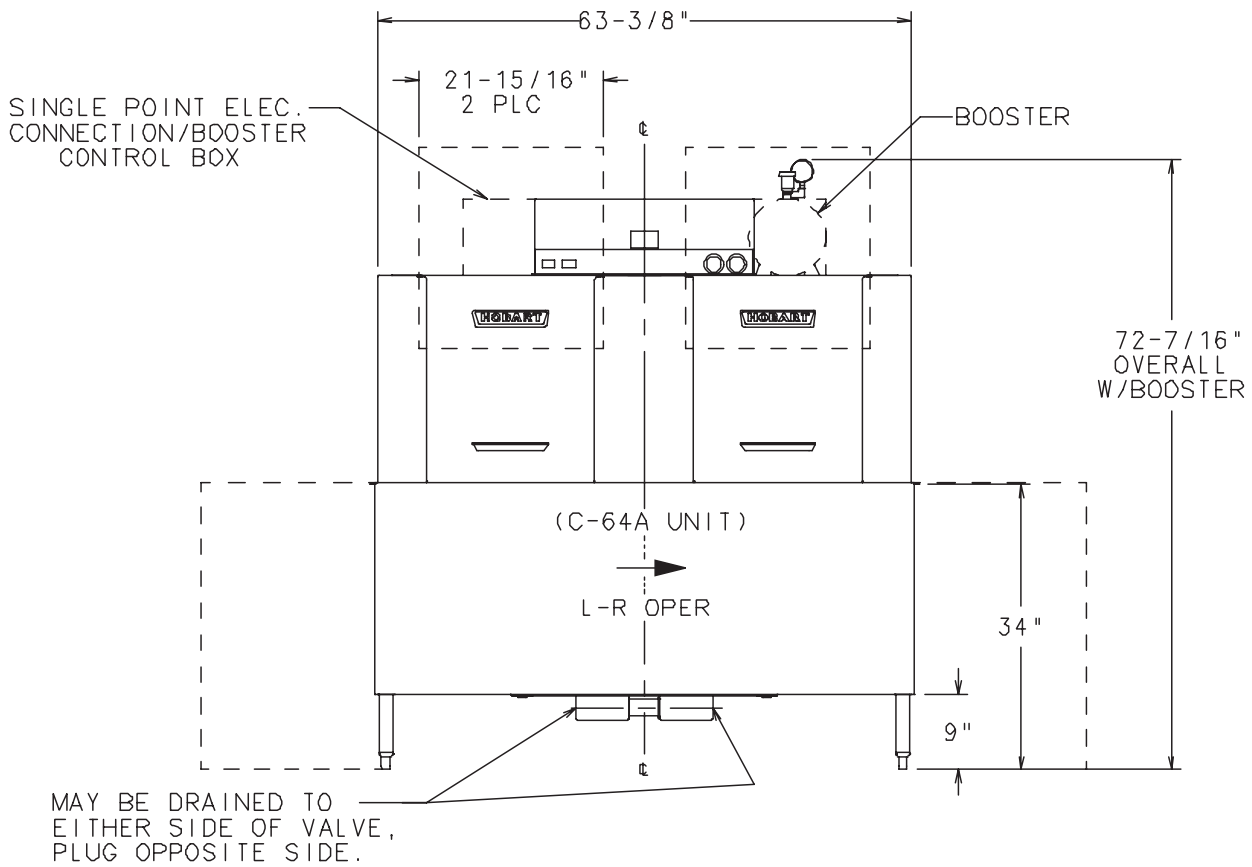



701 S Ridge Avenue, Troy, OH 45374  
1-888-4HOBART • www.hobartcorp.com

# C64A DISHWASHER

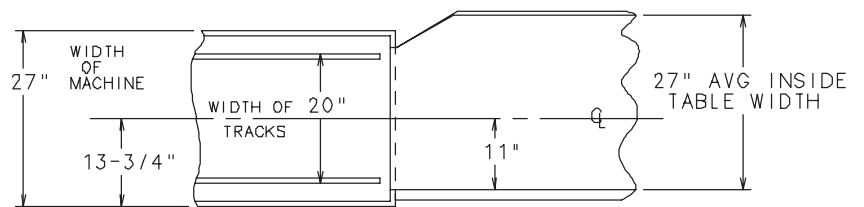
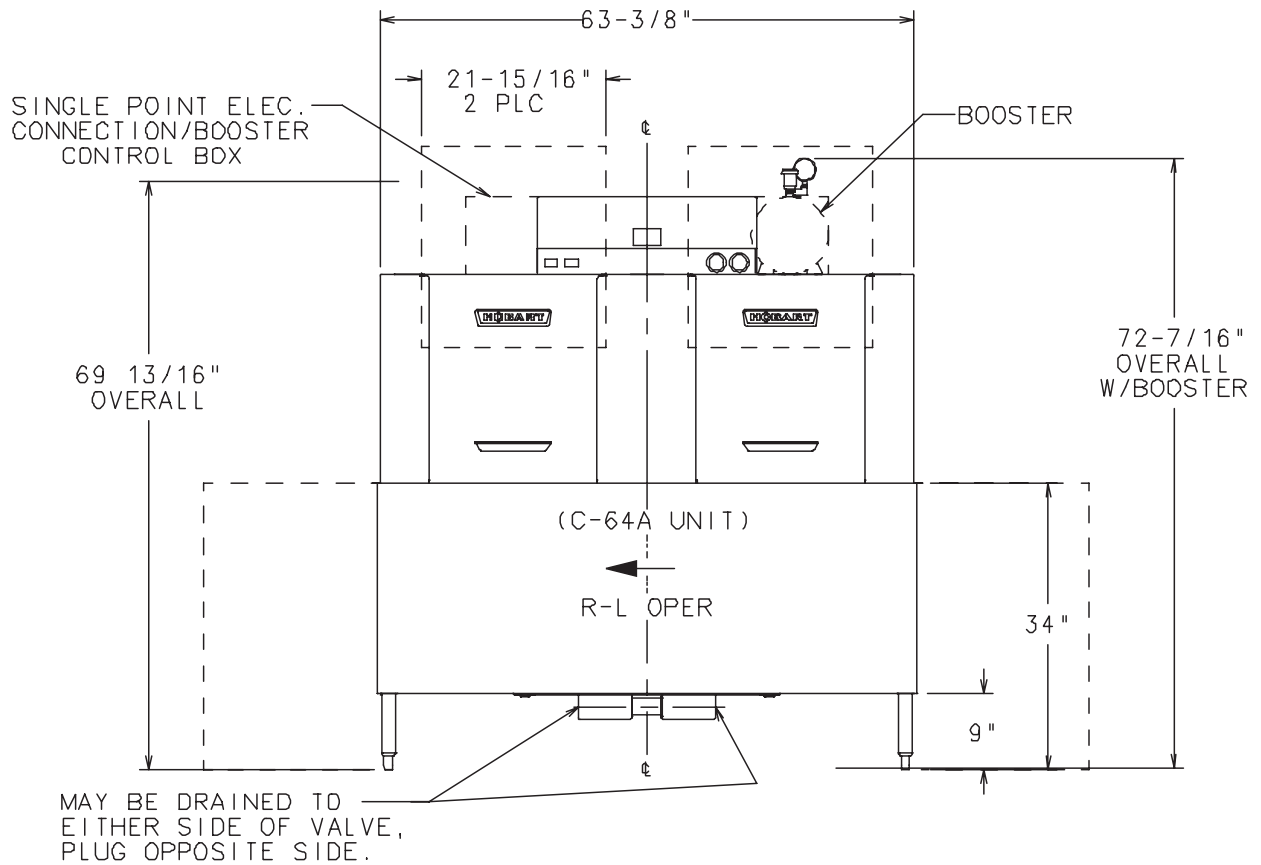

SUGGESTED TRACK AND TABLE LAYOUT

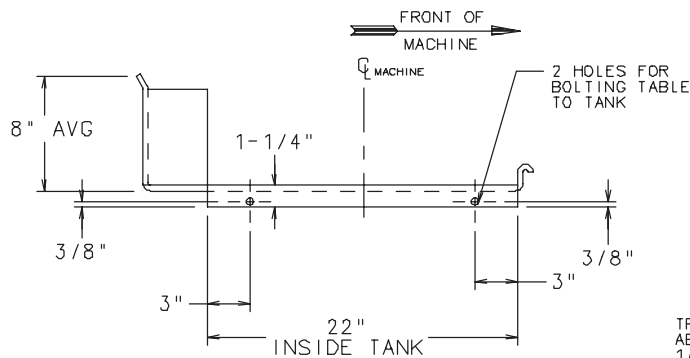

VIEW SHOWING HOLE LOCATIONS IN TURNED DOWN PORTION OF TABLE

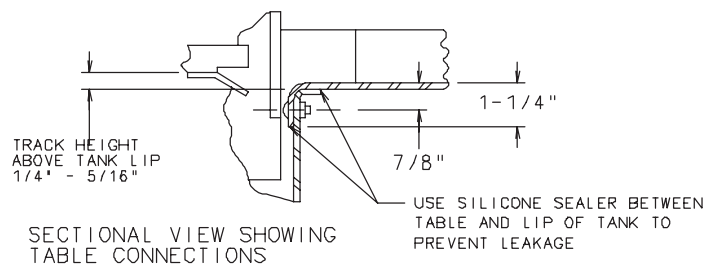

SECTIONAL VIEW SHOWING TABLE CONNECTIONS

# C64A ELECTRIC L-R



701 S Ridge Avenue, Troy, OH 45374  
1-888-4HOBART • www.hobartcorp.com

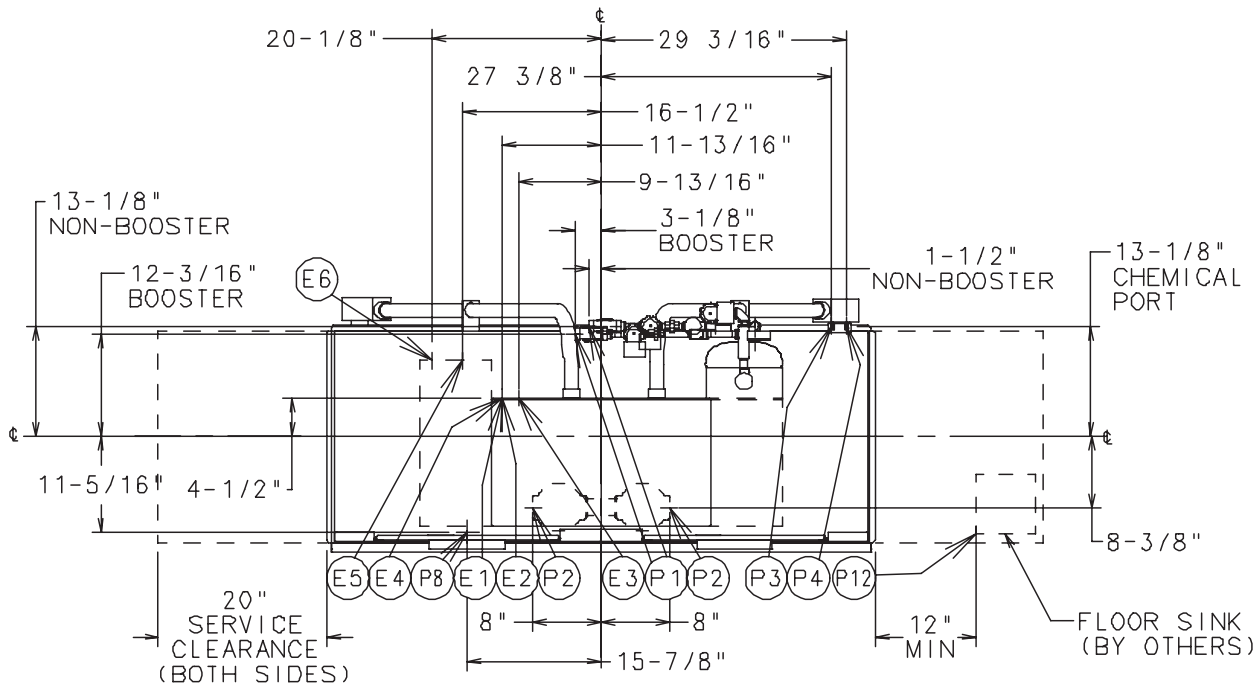

MODEL: C-64A  
L-R OPERATION  
D-328050  
REV. M

**PLUMBING NOTES:**

- WATER HAMMER ARRESTOR (MEETING ASSE-1010 STANDARD OR EQUIVALENT) TO BE SUPPLIED (BY OTHERS) IN COMMON WATER SUPPLY LINE AT SERVICE CONNECTION.
- RECOMMENDED WATER HARDNESS TO BE 4-6 GRAINS FOR BEST RESULTS.
- RECOMMENDED BUILDING FLOWING WATER PRESSURE TO THE DISHWASHER IS 20 PSI. (15 PSI MIN - 25 PSI MAX). IF PRESSURES HIGHER THAN 25 PSI ARE PRESENT, A PRESSURE REGULATING VALVE WITH INTERNAL THERMAL EXPANSION BY PASS, MUST BE SUPPLIED (BY OTHERS) IN THE WATER LINE TO THE DISHWASHER.
- FOR CONVENIENCE WHEN CLEANING, WATER TAP SHOULD BE INSTALLED NEAR MACHINE WITH HEAVY DUTY HOSE AND SQUEEZE VALVE.
- DISHWASHER MUST BE INSTALLED AND OPERATED ONLY WITH CHEMICAL SANITIZING FEEDER THAT IS LISTED BY NSF INTERNATIONAL.
- WHEN REQUIRED, INSTALL FLOOR SINK OUTSIDE THE PERIMETER OF THE DISHWASHER

**MISCELLANEOUS NOTES:**

- WHEN VENT HOODS OR EXTENDED HOODS ARE ORDERED, REFER TO C-LINE VENTS AND HOODS SPECIFICATION SHEET (FORM F-7841) FOR DETAILS AND CONNECTIONS.
- EXHAUST REQUIREMENTS: 200 CFM ENTRANCE END  
400 CFM EXIT END.
- ALL DIMENSIONS TAKEN FROM FLOOR LINE MAY BE INCREASED APPROXIMATELY 3/4" OR DECREASED 1/2".
- 63-7/8" INSIDE TANK (AT TABLE CONNECTION)  
63-21/32" TABLE TO TABLE.
- NET WEIGHT OF MACHINE: 660 LBS.  
DOMESTIC SHIPPING WEIGHT: 880 LBS.

**WARNING**

ELECTRICAL AND GROUNDING CONNECTIONS MUST COMPLY WITH THE APPLICABLE PORTIONS OF THE NATIONAL ELECTRICAL CODE AND/OR OTHER LOCAL ELECTRICAL CODES.

PLUMBING CONNECTIONS MUST COMPLY WITH APPLICABLE SANITARY, SAFETY, AND PLUMBING CODES.

MOTORS: 1/6 HP CONVEYOR  
2.0 HP WASH  
2.0 HP RINSE

ELECTRIC SPECS.	RATED AMPS	MINIMUM SUPPLY CIRCUIT CONDUCTOR AMPACITY	MAXIMUM PROTECTIVE DEVICE
208-240/60/1	24.6	35	35
208-240/60/3	16.8	25	25
480/60/3	9.4	15	15

SEPARATE SERVICE CONNECTION FOR ELEC. HEAT

ELEC. HEAT 15 KW (WASH)			
ELEC. SPECS.	RATED AMPS	MINIMUM SUPPLY CIRCUIT CONDUCTOR AMPACITY	MAXIMUM PROTECTIVE DEVICE
208/60/1	77.9	100	100
240/60/1	74.2	100	100
208/60/3	44.9	60	60
240/60/3	42.8	60	60
480/60/3	21.4	30	30

SEPARATE SERVICE CONNECTION FOR ELEC. HEAT

ELEC. HEAT 10 KW (RINSE)			
ELEC. SPECS.	RATED AMPS	MINIMUM SUPPLY CIRCUIT CONDUCTOR AMPACITY	MAXIMUM PROTECTIVE DEVICE
208/60/1	52.0	70	70
240/60/1	49.6	70	70
208/60/3	30.0	40	40
240/60/3	28.6	40	40
480/60/3	14.3	20	20

SINGLE POINT ELECTRICAL CONNECTION (3 PH ONLY) MOTORS AND ELECTRIC TANK HEAT

ELECTRIC SPECS.	RATED AMPS	MINIMUM SUPPLY CIRCUIT CONDUCTOR AMPACITY	MAXIMUM PROTECTIVE DEVICE
208/60/3	91.7	125	125
240/60/3	88.2	125	125
480/60/3	45.1	60	60



701 S Ridge Avenue, Troy, OH 45374  
1-888-4HOBART • www.hobartcorp.com

# C64A ELECTRIC R-L

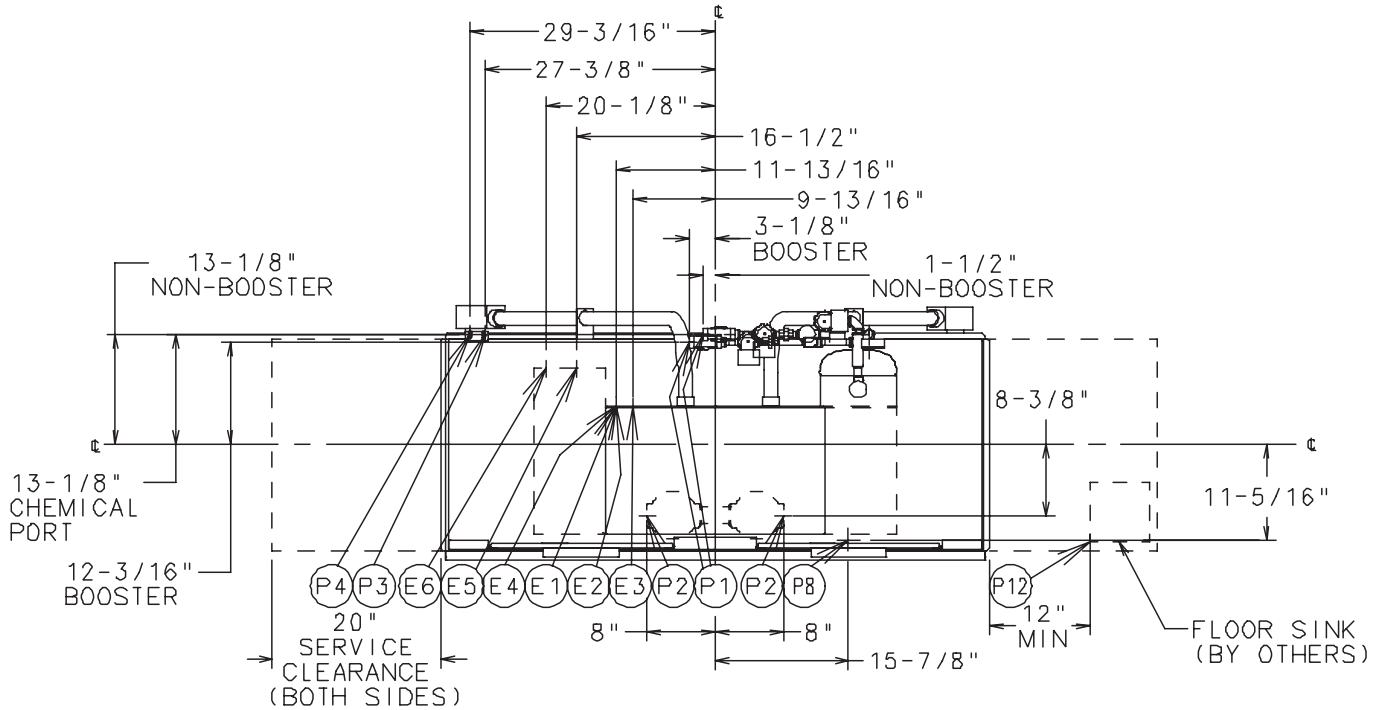

CAUTION: CERTAIN MATERIALS INCLUDING SILVER, ALUMINUM, AND PEWTER ARE ATTACKED BY SODIUM HYPOCHLORITE (LIQUID BLEACH).

MODEL: C-64A  
R-L OPERATION  
D-328049  
REV. M

BOOSTER HEAT 15 KW			
ELEC. SPECS.	RATED AMPS	MINIMUM SUPPLY CIRCUIT CONDUCTOR AMPACITY	MAXIMUM PROTECTIVE DEVICE
200-240/50/3	40.1	50	50
380-415/50/3	26.6	30	30
200/50/3	43.3	60	60
208-240/60/3	40.1	50	50
208/60/3	45.0	60	60
240/60/3	40.1	50	50
380/60/3	21.3	30	30
380-415/60/3	23.2	30	30
480/60/3	20.0	25	25
600/60/3	13.5	20	20

BOOSTER HEAT 30 KW			
ELEC. SPECS.	RATED AMPS	MINIMUM SUPPLY CIRCUIT CONDUCTOR AMPACITY	MAXIMUM PROTECTIVE DEVICE
200-240/50/3	80.2	90	90
380-415/50/3	53.2	60	60
200/50/3	80.8	90	90
208-240/60/3	80.2	90	90
208/60/3	83.9	90	90
240/60/3	80.2	90	90
380/60/3	42.5	60	60
380-415/60/3	46.4	60	60
480/60/3	40.1	50	50
600/60/3	33.7	40	40

## CONNECTION INFORMATION (\*AFF - ABOVE FINISHED FLOOR)

### LEGEND

- E1 ELECTRIC HEAT : 15,000 WATTS, WASH TANK. 1" CONDUIT HOLE, 63-5/8" AFF.
- E2 ELECTRIC HEAT : 10,000 WATTS, RINSE TANK. 1" CONDUIT HOLE, 61-7/8" AFF.
- E3 ELECTRIC CONNECTION: DETERGENT, SANITIZER (LOW TEMP ONLY) AND RINSE FEEDERS. 1/2" CONDUIT, 65-1/2" AFF
- E4 ELECTRIC CONNECTION: MOTORS AND CONTROLS 3/4" CONDUIT, 65-1/2" AFF.
- E5 SINGLE POINT ELECTRIC CONNECTION: (ELECTRIC HEAT ONLY, WHEN ORDERED) 2" CONDUIT, 62-1/16" AFF
- E6 ELECTRIC CONNECTION: BOOSTER. 15KW/30KW, 1-1/4" CONDUIT HOLE, 63-5/8" AFF
- P1 COMMON WATER CONNECTION: HIGH TEMP OPERATION - 180°F WATER MIN, WITHOUT BUILT-IN BOOSTER HEATER, 110°F WATER MIN. WITH BUILT-IN BOOSTER HEATER; LOW TEMP OPERATION - 140°F WATER MIN. 3/4" FPT, 63-7/8" AFF.
- P2 DRAIN: 2" FPT, 7-3/8" AFF TWO CONNECTIONS.
- P3 SANITIZER FEEDER: REMOVE 1/8" NPT PIPE PLUG TO ACCESS TAPPED HOLE. 1/8" NPT 59-1/8" AFF (LOW TEMP)
- P4 RINSE FEEDER: REMOVE 1/8" NPT PIPE PLUG TO ACCESS TAPPED HOLE. 1/8" NPT 60-5/8" AFF (59-1/8" AFF LOW TEMP)
- P8 DETERGENT PROBE SENSOR: REMOVE CAP AND STUD ASSEMBLY TO ACCESS 7/8" DIA HOLE (WASH TANK ONLY). 12-5/16" AFF.
- P12 INDIRECT DRAIN-FLOOR SINK: BY OTHERS, 0" AFF.



# C64A GAS L-R

# HOBART

701 S Ridge Avenue, Troy, OH 45374  
1-888-4HOBART • www.hobartcorp.com

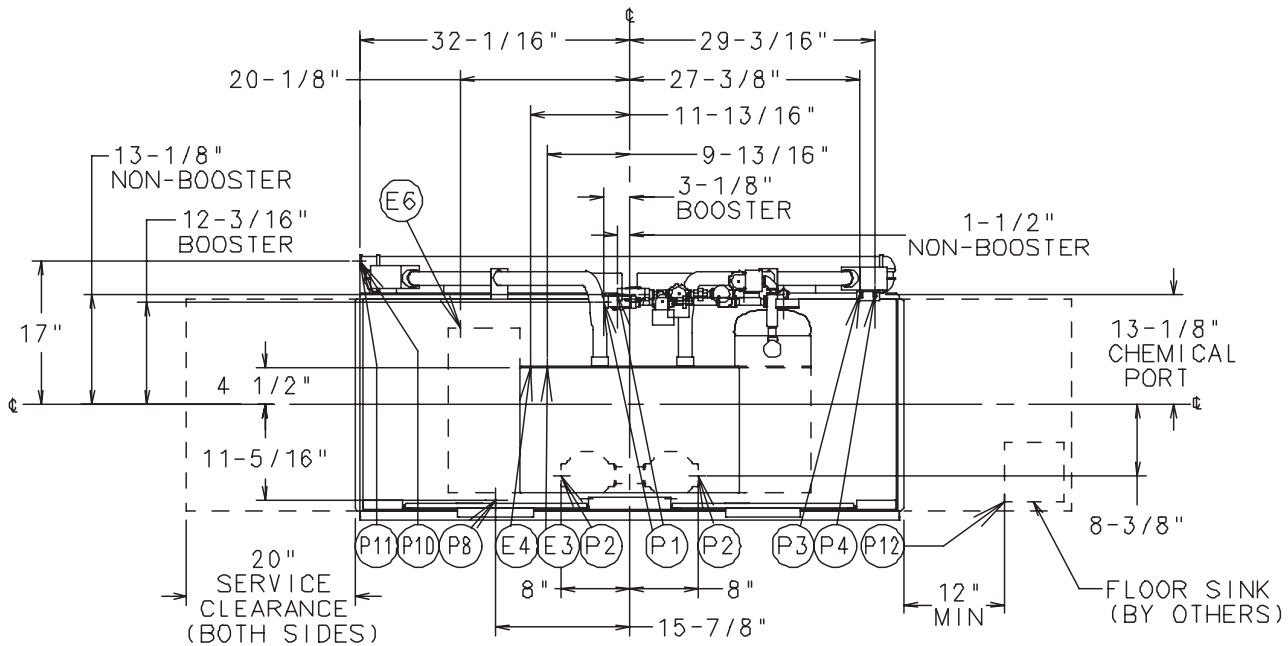

## GAS HEATED DISHWASHERS

FOR NATURAL GAS, PRESSURE TO THE BURNER (CUSTOMER CONNECTION) SHOULD NOT EXCEED 7" W.C.

FOR LP GAS, PRESSURE TO THE BURNER (CUSTOMER CONNECTION) SHOULD NOT EXCEED 11" W.C.

IF GAS PRESSURE IS HIGHER THAN 7"(NAT) OR 11"(LP) W.C., A PRESSURE REGULATING VALVE MUST BE INSTALLED (BY OTHERS) IN THE GAS LINE TO THE DISHWASHER.

GAS HEAT (NATURAL OR LP) BTU INPUT - 94,000.

WHEN GAS TANK HEAT IS SPECIFIED, GAS EXHAUST VENTING MUST BE INSTALLED ACCORDING TO LOCAL CODE. DO NOT CONNECT FLUE TO POWER VENT.

## PLUMBING NOTES:

WATER HAMMER ARRESTOR (MEETING ASSE-1010 STANDARD OR EQUIVALENT) TO BE SUPPLIED (BY OTHERS) IN COMMON WATER SUPPLY LINE AT SERVICE CONNECTION.

RECOMMENDED WATER HARDNESS TO BE 4-6 GRAINS FOR BEST RESULTS.

RECOMMENDED BUILDING FLOWING WATER PRESSURE TO THE DISHWASHER IS 20 PSI, (15 PSI MIN - 25 PSI MAX).

IF PRESSURES HIGHER THAN 25 PSI ARE PRESENT, A PRESSURE REGULATING VALVE WITH INTERNAL THERMAL EXPANSION BY PASS, MUST BE SUPPLIED (BY OTHERS) IN THE WATER LINE TO THE DISHWASHER.

FOR CONVENIENCE WHEN CLEANING, WATER TAP SHOULD BE INSTALLED NEAR MACHINE WITH HEAVY DUTY HOSE AND SQUEEZE VALVE.

DISHWASHER MUST BE INSTALLED AND OPERATED ONLY WITH CHEMICAL SANITIZING FEEDER THAT IS LISTED BY NSF INTERNATIONAL.

## MISCELLANEOUS NOTES:

WHEN VENT HOODS OR EXTENDED HOODS ARE ORDERED, REFER TO C-LINE VENTS AND HOODS SPECIFICATION SHEET (FORM F-7841) FOR DETAILS AND CONNECTIONS.  
EXHAUST REQUIREMENTS: 200 CFM ENTRANCE END  
400 CFM EXIT END.

ALL DIMENSIONS TAKEN FROM FLOOR LINE MAY BE INCREASED APPROXIMATELY 3/4" OR DECREASED 1/2".

63-7/8" INSIDE TANK (AT TABLE CONNECTION)  
63-21/32" TABLE TO TABLE.

## WARNING

ELECTRICAL AND GROUNDING CONNECTIONS MUST COMPLY WITH THE APPLICABLE PORTIONS OF THE NATIONAL ELECTRICAL CODE AND/OR OTHER LOCAL ELECTRICAL CODES.

PLUMBING CONNECTIONS MUST COMPLY WITH APPLICABLE SANITARY, SAFETY, AND PLUMBING CODES.

CAUTION: CERTAIN MATERIALS INCLUDING SILVER, ALUMINUM, AND PEWTER ARE ATTACKED BY SODIUM HYPOCHLORITE (LIQUID BLEACH).

MOTORS: 1/6 HP CONVEYOR  
2.0 HP WASH  
2.0 HP RINSE

ELECTRIC SPECS.	RATED AMPS	MINIMUM SUPPLY CIRCUIT CONDUCTOR AMPACITY	MAXIMUM PROTECTIVE DEVICE
208-240/60/1	24.6	35	35
208-240/60/3	16.8	25	25
480/60/3	9.4	15	15





701 S Ridge Avenue, Troy, OH 45374  
1-888-4HOBART • www.hobartcorp.com

**C64A  
GAS R-L**

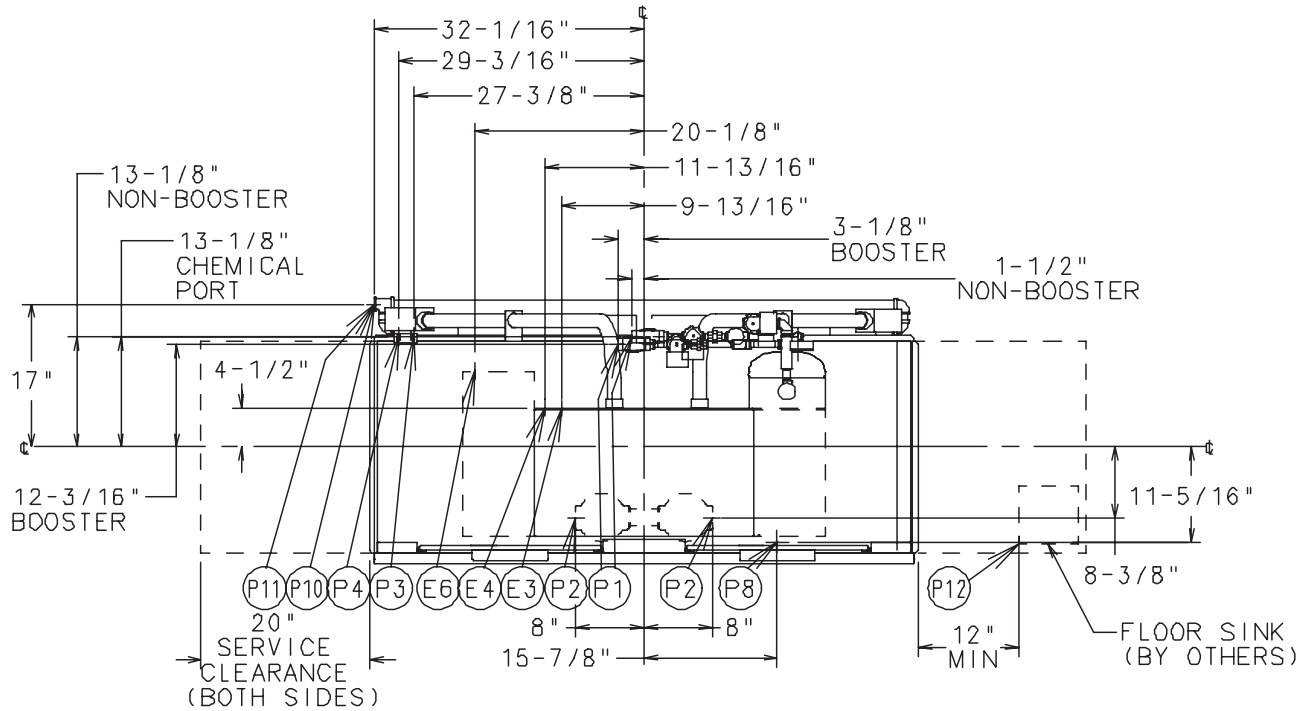

BOOSTER HEAT 15 KW			
ELEC. SPECS.	RATED AMPS	MINIMUM SUPPLY CIRCUIT CONDUCTOR AMPACITY	MAXIMUM PROTECTIVE DEVICE
200-240/50/3	40.1	50	50
380-415/50/3	26.6	30	30
200/50/3	43.3	60	60
208-240/60/3	40.1	50	50
208/60/3	45.0	60	60
240/60/3	40.1	50	50
380/60/3	21.3	30	30
380-415/60/3	23.2	30	30
480/60/3	20.0	25	25
600/60/3	13.5	20	20

BOOSTER HEAT 30 KW			
ELEC. SPECS.	RATED AMPS	MINIMUM SUPPLY CIRCUIT CONDUCTOR AMPACITY	MAXIMUM PROTECTIVE DEVICE
200-240/50/3	80.2	90	90
380-415/50/3	53.2	60	60
200/50/3	80.8	90	90
208-240/60/3	80.2	90	90
208/60/3	83.9	90	90
240/60/3	80.2	90	90
380/60/3	42.5	60	60
380-415/60/3	46.4	60	60
480/60/3	40.1	50	50
600/60/3	33.7	40	40

CONNECTION INFORMATION  
(\*AFF - ABOVE FINISHED FLOOR)

LEGEND

- E3 ELECTRIC CONNECTION: DETERGENT, SANITIZER (LOW TEMP ONLY) AND RINSE FEEDERS. 1/2" CONDUIT. 65-1/2" AFF
- E4 ELECTRIC CONNECTION: MOTORS AND CONTROLS 3/4" CONDUIT. 65-1/2" AFF.
- E6 ELECTRIC CONNECTION: BOOSTER. 15KW/30KW, 1-1/4" CONDUIT HOLE, 63-5/8" AFF
- P1 COMMON WATER CONNECTION: HIGH TEMP OPERATION - 180°F WATER MIN. WITHOUT BUILT-IN BOOSTER HEATER; 110°F WATER MIN. WITH BUILT-IN BOOSTER HEATER; LOW TEMP OPERATION - 140°F WATER MIN. 3/4" FPT, 63-7/8" AFF.
- P2 DRAIN: 2" FPT, 7-3/8" AFF TWO CONNECTIONS.
- P3 SANITIZER FEEDER: REMOVE 1/8" NPT PIPE PLUG TO ACCESS TAPPED HOLE. 1/8" NPT 59-1/8" AFF (LOW TEMP)
- P4 RINSE FEEDER: REMOVE 1/8" NPT PIPE PLUG TO ACCESS TAPPED HOLE. 1/8" NPT 60-5/8" AFF (59-1/8" AFF LOW TEMP)
- P8 DETERGENT PROBE SENSOR: REMOVE CAP AND STUD ASSEMBLY TO ACCESS 7/8" DIA HOLE (WASH TANK ONLY). 12-5/16" AFF.
- P10 GAS CONNECTION - NAT.: 3/4" FPT, 7-3/4" AFF.
- P11 GAS CONNECTION - L.P.: 3/4" FPT, 7-3/4" AFF.
- P12 INDIRECT DRAIN-FLOOR SINK: BY OTHERS, 0" AFF.

# C64A STEAM L-R



701 S Ridge Avenue, Troy, OH 45374  
1-888-4HOBART • www.hobartcorp.com

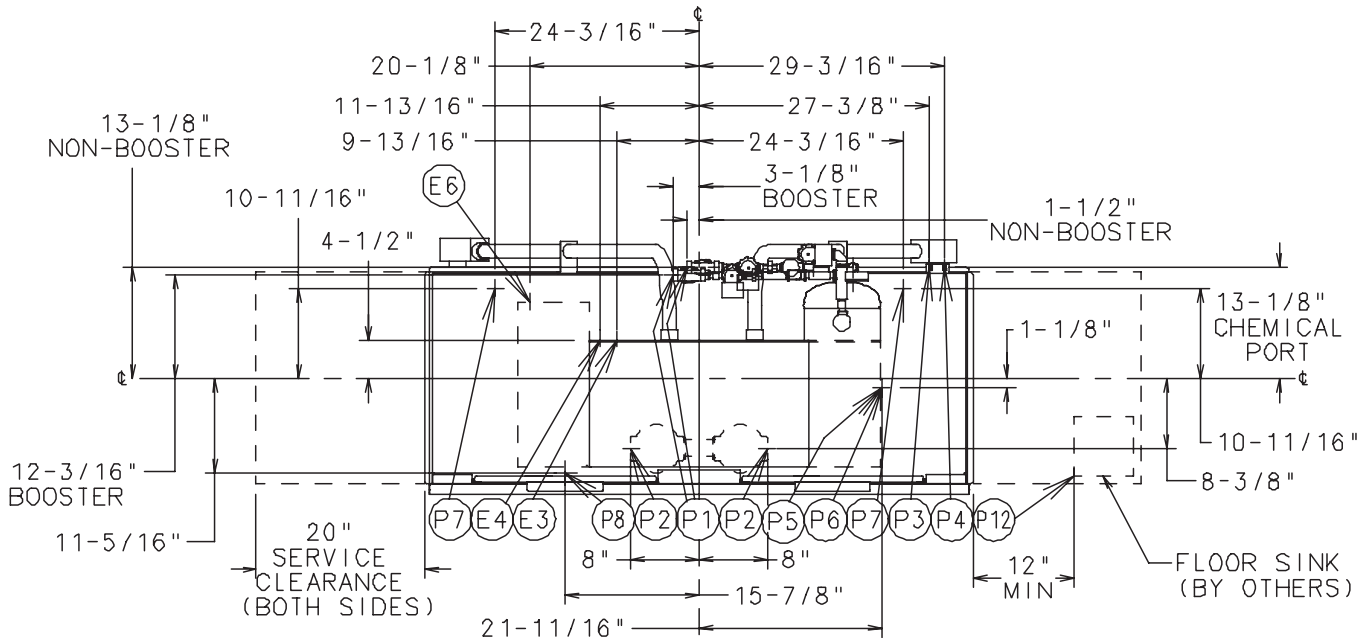

**PLUMBING NOTES:**

- WATER HAMMER ARRESTOR (MEETING ASSE-1010 STANDARD OR EQUIVALENT) TO BE SUPPLIED (BY OTHERS) IN COMMON WATER SUPPLY LINE AT SERVICE CONNECTION.
- RECOMMENDED WATER HARDNESS TO BE 4-6 GRAINS FOR BEST RESULTS.
- RECOMMENDED BUILDING FLOWING WATER PRESSURE TO THE DISHWASHER IS 20 PSI, (15 PSI MIN - 25 PSI MAX). IF PRESSURES HIGHER THAN 25 PSI ARE PRESENT, A PRESSURE REGULATING VALVE WITH INTERNAL THERMAL EXPANSION BY PASS, MUST BE SUPPLIED (BY OTHERS) IN THE WATER LINE TO THE DISHWASHER.
- FOR CONVENIENCE WHEN CLEANING, WATER TAP SHOULD BE INSTALLED NEAR MACHINE WITH HEAVY DUTY HOSE AND SQUEEZE VALVE.
- DISHWASHER MUST BE INSTALLED AND OPERATED ONLY WITH CHEMICAL SANITIZING FEEDER THAT IS LISTED BY NSF INTERNATIONAL.
- FLOWING STEAM PRESSURES ABOVE 50 PSI MUST HAVE A PRESSURE REGULATOR (NOT SUPPLIED) INSTALLED IN THE STEAM LINE.
- SHUT OFF VALVE MUST BE SUPPLIED (BY OTHERS) IN THE STEAM LINE TO THE DISHWASHER.
- WHEN REQUIRED, INSTALL FLOOR SINK OUTSIDE THE PERIMETER OF THE DISHWASHER

**MISCELLANEOUS NOTES:**

- WHEN VENT HOODS OR EXTENDED HOODS ARE ORDERED, REFER TO C-LINE VENTS AND HOODS SPECIFICATION SHEET (FORM F-7841) FOR DETAILS AND CONNECTIONS.
- EXHAUST REQUIREMENTS: 200 CFM ENTRANCE END  
400 CFM EXIT END.
- ALL DIMENSIONS TAKEN FROM FLOOR LINE MAY BE INCREASED APPROXIMATELY 3/4" OR DECREASED 1/2".
- 63-7/8" INSIDE TANK (AT TABLE CONNECTION)
- 63-21/32" TABLE TO TABLE.

**WARNING**

ELECTRICAL AND GROUNDING CONNECTIONS MUST COMPLY WITH THE APPLICABLE PORTIONS OF THE NATIONAL ELECTRICAL CODE AND/OR OTHER LOCAL ELECTRICAL CODES.

PLUMBING CONNECTIONS MUST COMPLY WITH APPLICABLE SANITARY, SAFETY, AND PLUMBING CODES.

**CAUTION:** CERTAIN MATERIALS INCLUDING SILVER, ALUMINUM, AND PEWTER ARE ATTACKED BY SODIUM HYPOCHLORITE (LIQUID BLEACH).

MOTORS: 1/6 HP CONVEYOR  
2.0 HP WASH  
2.0 HP RINSE

ELECTRIC SPECS.	RATED AMPS	MINIMUM SUPPLY CIRCUIT CONDUCTOR AMPACITY	MAXIMUM PROTECTIVE DEVICE
208-240/60/1	24.6	35	35
208-240/60/3	16.8	25	25
480/60/3	9.4	15	15



701 S Ridge Avenue, Troy, OH 45374  
1-888-4HOBART • www.hobartcorp.com

# C64A STEAM R-L

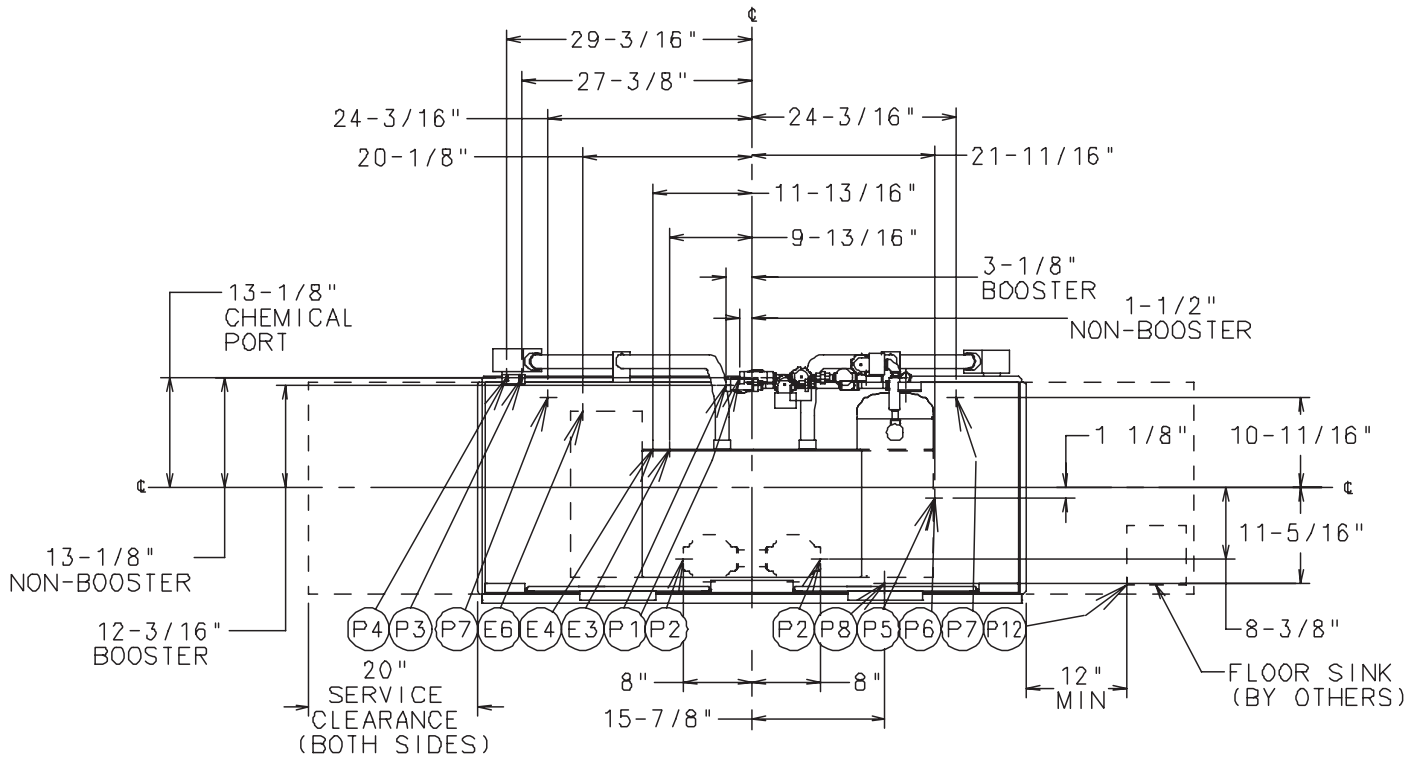

BOOSTER HEAT 15 KW			
ELEC. SPECS.	RATED AMPS	MINIMUM SUPPLY CIRCUIT CONDUCTOR AMPACITY	MAXIMUM PROTECTIVE DEVICE
200-240/50/3	40.1	50	50
380-415/50/3	26.6	30	30
200/50/3	43.3	60	60
208-240/60/3	40.1	50	50
208/60/3	45.0	60	60
240/60/3	40.1	50	50
380/60/3	21.3	30	30
380-415/60/3	23.2	30	30
480/60/3	20.0	25	25
600/60/3	13.5	20	20

BOOSTER HEAT 30 KW			
ELEC. SPECS.	RATED AMPS	MINIMUM SUPPLY CIRCUIT CONDUCTOR AMPACITY	MAXIMUM PROTECTIVE DEVICE
200-240/50/3	80.2	90	90
380-415/50/3	53.2	60	60
200/50/3	80.8	90	90
208-240/60/3	80.2	90	90
208/60/3	83.9	90	90
240/60/3	80.2	90	90
380/60/3	42.5	60	60
380-415/60/3	46.4	60	60
480/60/3	40.1	50	50
600/60/3	33.7	40	40

### CONNECTION INFORMATION (\*AFF - ABOVE FINISHED FLOOR)

#### LEGEND

- E3 ELECTRIC CONNECTION: DETERGENT, SANITIZER (LOW TEMP ONLY) AND RINSE FEEDERS. 1/2" CONDUIT. 65-1/2" AFF
- E4 ELECTRIC CONNECTION: MOTORS AND CONTROLS 3/4" CONDUIT. 65-1/2" AFF
- E6 ELECTRIC CONNECTION: BOOSTER. 15KW/30KW, 1-1/4" CONDUIT HOLE, 63-5/8" AFF
- P1 COMMON WATER CONNECTION: HIGH TEMP OPERATION - 180°F WATER MIN. WITHOUT BUILT-IN BOOSTER HEATER, 110°F WATER MIN. WITH BUILT-IN BOOSTER HEATER; LOW TEMP OPERATION - 140°F WATER MIN. 3/4" FPT, 63-7/8" AFF.
- P2 DRAIN: 2" FPT, 7-3/8" AFF TWO CONNECTIONS.
- P3 SANITIZER FEEDER: REMOVE 1/8" NPT PIPE PLUG TO ACCESS TAPPED HOLE. 1/8" NPT 59-1/8" AFF (LOW TEMP)
- P4 RINSE FEEDER: REMOVE 1/8" NPT PIPE PLUG TO ACCESS TAPPED HOLE. 1/8" NPT 60-5/8" AFF (59-1/8" AFF LOW TEMP)
- P5 STEAM INJECTOR (WHEN ORDERED): 10 TO 25 PSI FLOWING, 50 PSI MAX., 1-1/2" FPT, 7-15/16" AFF.
- P6 STEAM COILS (WHEN ORDERED): 10 TO 25 PSI FLOWING, 50 PSI MAX., 1-1/2" FPT, 7-15/16" AFF.
- P7 CONDENSATE RETURN (STEAM COILS WHEN ORDERED): 10 TO 50 PSI FLOWING PRESSURE, 3/4" FPT, 7-1/16" AFF TWO CONNECTIONS. (TWO BUCKET TYPE TRAPS FURNISHED).
- P8 DETERGENT PROBE SENSOR: REMOVE CAP AND STUD ASSEMBLY TO ACCESS 7/8" DIA HOLE (WASH TANK ONLY). 12-5/16" AFF.
- P12 INDIRECT DRAIN-FLOOR SINK: BY OTHERS, 0" AFF.

# C64A DISHWASHER



701 S Ridge Avenue, Troy, OH 45374  
1-888-4HOBART • www.hobartcorp.com

**DESIGN:** Fully automatic, high-temperature two-tank, rack-type dishwasher with flexible strip curtains at ends of chamber and between wash, power rinse and final rinse compartments. Two large inspection doors located in front of machine provide easy access to wash arms, power rinse arms, rinse arms, rinse pan strainer, strainer baskets, front and rear strainers, and pump intake screens. Doors guided for ease of operation and long life. Design provides for changing of direction of operation in the field. Length of machine inside tank (at table connection) 64". Machine designed to clean and sanitize with hot water 150°F wash, 160°F power rinse, and 180°F (minimum) final rinse. Water hardness must be controlled to 4-6 gr. for best results. Automatic interlocks shut off pumps and conveyor if a door is opened when machine is in operation.

**CONSTRUCTION:** Tank and chamber constructed of #16 gauge stainless steel, arc-welded. Unitized, welded stainless steel tanks, frame and stainless steel legs. Chamber, control box, doors, and front trim panel are polished, satin finish.

**PUMPS:** Recirculating stainless steel pumps with stainless steel impeller and face seal with stainless steel metal components and ceramic seat. Readily removable motor/impeller assembly permits quick inspection. The pump is self-draining. All piping distributing water to the upper and lower wash arms or power rinse arms are stainless steel tubing.

**PUMP MOTORS:** Built for Hobart: wash and rinse motor, 2 horsepower, grease-packed ball bearings, splashproof, ventilated with manual resettable inherent overload protection in each motor. Available in electrical specifications of 208-240/60/3, 480/60/3. Also available are 200-240/50/1, 200-240/50/3, and 380-415/50/3, not submitted for UL Listing.

**CONTROLS:** A stainless steel control center with power "on/off" and "start/stop" switches is mounted on top of machine. All control circuit components will be operated from a 120 volt control circuit transformer. Auto-timer is standard equipment. An "auto/manual" switch is located on the left side of control box for bypassing the auto-timer feature. Electrical components are completely wired with 105°C, 600V thermoplastic insulated wire with stranded conductors routed through Listed electrical conduit or covered wireway built into the front of the machine above tank water level.

**CONVEYOR:** Dual rack drive, with stainless steel pawls both sides of conveyor, designed to eliminate interference with wash, power rinse, and rinse spray patterns. Racks conveyed automatically through wash, power rinse and rinse sections and onto clean dish table. Factory set overload mechanism on conveyor drive prevents damage to machine or racks, should movement of racks be obstructed. Rack tracks, conveyor structure, and drive units of stainless steel. Conveyor speed: 6.9 FPM.

**DRIVE MOTOR:** Built for Hobart, 1/2 horsepower gearmotor, ventilated with manual, resettable inherent overload protection. Available in electrical specifications of 208-240/60/3, 480/60/3. Also available, but not submitted for UL Listing are 200-240/50/1, 200-240/50/3, and 380-415/50/3.

**POWER WASH AND POWER RINSE:** Wash and rinse tanks are equipped with upper and lower stainless steel wash arms with specially shaped nozzles having large openings and arranged to effectively direct water jets to all ware surfaces. Both upper and lower arms, along with arm end caps, are easily removable for cleaning without use of tools. Removable perforated stainless steel strainer pans support a deep perforated stainless steel basket. Basket and strainer pans (2) can be removed without lower arm removal.

**FINAL RINSE:** Upper and lower rinse arms have single rows of nozzles. Rinse is automatically activated by racks in passing. Final rinse water line is equipped with vacuum breaker in downstream side of electrically operated solenoid valve in common piping system.

Design provides for routing of final rinse water after use to wash tank. Rinse agent dispenser injection port provided in final rinse piping above chamber. Final rinse flow rate: 2.21 GPM at 20 PSI.

**FILL:** Fill water line is equipped with vacuum breaker on downstream side of electrically operated solenoid valve in common piping system, for automatic maintenance of tank level. Fill is interrupted whenever a door is opened.

**DRAIN AND OVERFLOW:** Large bell-type automatic overflow and drain valve controlled from inside of machine. Drain automatically closed by lowering inspection door. Drain seal is large diameter, high temperature o-ring. Stainless steel drain seat. Common drain piping can be plumbed from load or unload end of machine.

**STANDARD EQUIPMENT:** Sealed dial-type thermometers indicate temperatures of wash, rinse and final rinse water. Positive low water protection for tank heat. Plastic strip curtains throughout machine. Stainless steel control box. Built-in wireway. Drain is automatically closed when inspection door is closed. Stainless steel adjustable feet. Stainless steel hang-on/drop-in-place front trim panel. Automatic tank fill. Door interlock. Auto-timer. Pilot circuit. Common drain. Vent fan and booster heater controls.

#### WASH TANK HEATING SELECTIONS (must choose one):

**ELECTRIC:** Two electric incoloy sheathed immersion heaters (15 KW and 10 KW) removable from inside tank. Tank water temperature is controlled by solid-state thermostat with positive low-water protection and magnetic contactor. (Disconnect switches not furnished.) Heating elements are additionally protected by a high limit device mounted on the surface of the element.

**STEAM:** One-inch stainless steel steam injectors or one-inch stainless steel steam coils (for contaminated steam). Tank water temperature controlled by solid-state thermostat with positive low-water protection. Steam supplied to machine through high temperature steam solenoid valve and line strainer. Each tank supplied through common steam connection.

**GAS:** Regulated power immersion tube gas burner system. Tank water temperature is controlled by solid-state thermostat, with positive low water protection. Immersion tube is additionally protected by a high limit device mounted on the surface of the tube. A solid-state ignitor board controls the gas valve and provides flame ignition for each tank. A transformer steps the control circuit voltage down from 120 volts to 24 volts to power the ignitor board and gas valve. Each tank supplied through common gas connection.

For natural gas, gas pressure to burner (customer connection) not to exceed 7" W.C.

For LP gas, gas pressure to burner (customer connection) not to exceed 11" W.C.

If gas pressure is higher than 7" W.C. natural or 11" W.C. LP, a pressure regulating valve must be supplied (by others) in the gas line to the dishwasher.

#### OPTIONAL EQUIPMENT AT EXTRA COST:

Stainless steel pressureless booster heater. Stainless steel vent hoods with vent stack and locking-type damper. Stainless steel extended hoods with vent stack and locking type damper. SL-23 and SL-30 without hood. Six inches higher than standard. Steam, gas or electric blower dryer (3-phase only). Floor-mounted steam or gas booster. Low temp final rinse system. 19 3/4" x 19 3/4" Hobart heavy-duty peg and combination and miscellaneous racks.

Single-point electrical connection for electric heat machine (3-phase only, does not include booster heater). Conveyor dwell. Table limit switch.

As continued product improvement is a policy of Hobart, specifications are subject to change without notice.